

DETACHABLE

DEDICATED COUPLING DETACHABLE JOINT (DJ) & VARIABLE ADAPTOR (VA) STRAIGHT & STEPPED PIPE JOINTING SOLUTIONS



	Detachable Joint (DJ), Straight Coupling	Variable Adaptor (VA), Stepped Coupling
In Brief	<ul style="list-style-type: none"> ▶ Dedicated Straight & Stepped Couplings for Joining Plain Ended Pipes ▶ Standard Long Collar Product Design is Ideal for Pipe Laying, Maintenance & Works Repair for All Installations ▶ Maximum Temperature -10°C To 70°C ▶ Working Pressure PN 10/16 ▶ Suitable for Potable Water, Neutral Liquids and Sewage ▶ Fusion Bonded Epoxy ▶ Seal : EPDM 	
Standards	<ul style="list-style-type: none"> ▶ Design : SPESIFIKASI JKR 20200-0045-99 ▶ Test : EN 12266-1 ▶ TYPE A : For AC (MS 712, AS 1711) & MS (JKR) Pipes ▶ TYPE B : For UPVC (MS 628, BS 6920) & MS (BS 534, AS 1579, SPAN TS 21827) Pipes ▶ TYPE D : For TYPE A To TYPE B Pipe Materials 	
	▶ Pipe Materials with Similar OD	▶ Pipe Materials with Different OD
Features	<ul style="list-style-type: none"> ▶ Range of DJ & VA Joint Sizes : DN80 to DN300 ▶ Quick, Reliable & Cost-Effective Jointing Solutions for Rigid Pipe Materials ▶ Leak Free Sealing by O-Ring Type Rubber Gasket 	



LYE MANUFACTURING SDN.BHD. (197701001852 (32836-H))
 Manufacturer of Valves, Hydrants, Joints, Fittings & Manhole Covers

**DEDICATED COUPLING
DETACHABLE JOINT (DJ) & VARIABLE ADAPTOR (VA)
STRAIGHT & STEPPED PIPE JOINTING SOLUTIONS**

Technical Table

Detachable Joint (DJ)

Type A

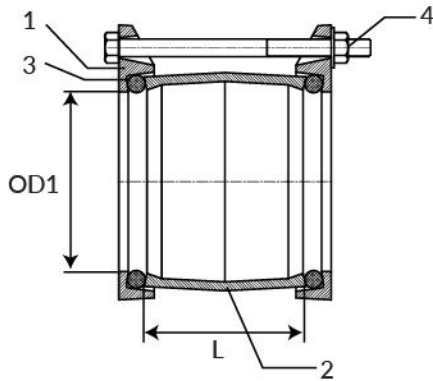

Type B

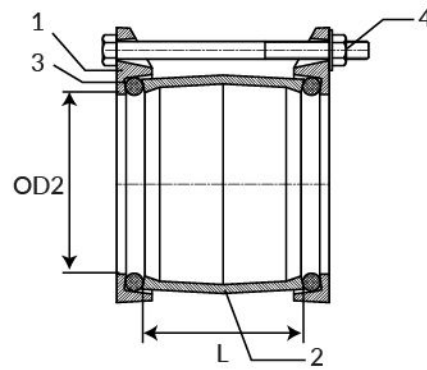

Variable Adaptor (VA)

Type D

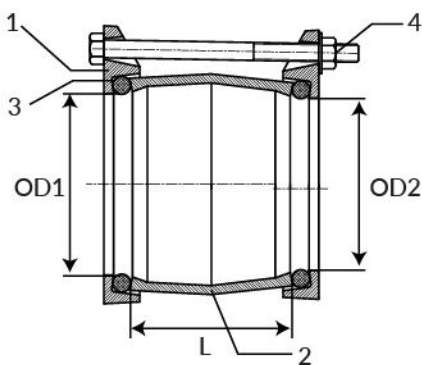

Assembly Chart

No.	Component	Material	Standard Ref.
1	Gland Flange	Ductile Iron	BS EN 1563
2	Sleeve / Collar	Ductile Iron	BS EN 1563
3	Gasket	EPDM	BS EN 681
4	Bolt & Nut	Hot Dipped Galvanized Steel	BS EN 4190

**Specifications & Parameters Chart
for DJ Joints, Type A & B & VA Joints, Type D**

DN (mm)	OD1 (mm)	OD2 (mm)	L (mm)	Bolts
80	95.6	88.9	100	M12x4
100	121.9/*125	114.3	110	M12x4
150	177.3/*180	168.3	130	M12x4
200	232.2	219.1	150	M12x4
250	286.0	273.0	165	M12x4
300	345.4	323.9	170	M12x5

*Good installation practice may be required, contact LYE for further advise.

Jointing Assembly

Detachable Joint (DJ) Straight Coupling	Variable Adaptor (VA) Stepped Coupling
--------------------------------------------	-------------------------------------------

OD1 to OD1 = TYPE A
OD2 to OD2 = TYPE B

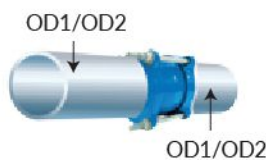

OD1 to OD 2 = TYPE D

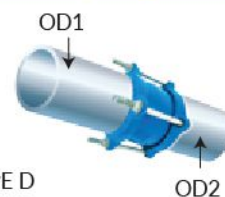

Note: Technical data provided in this brochure is indicative only and may be subject to change without prior notice.



LYE MANUFACTURING SDN.BHD. (197701001852 (32836-H))

Manufacturer of Valves, Hydrants, Joints, Fittings & Manhole Covers

Lot 1844, Jalan KPB 8, Kampung Baru Balakong, 43300 Kajang, Selangor Darul Ehsan, Malaysia.

FACTORY Tel: 603 - 8961 1623 Fax: 603 - 8961 1092 SALES Tel: 603 - 6140 3131(Hunting Line) Fax: 603 - 6140 5858

EMAIL: enquiry@lye.com.my

