



# DIRECT DRILL & TAP FERROUS SADDLES

FOR SERVICE CONNECTION & PRESSURE PIPE TAPPING THREADED INTERNALLY



Narrow Saddle Body



Broad Saddle Body



## In Brief

- ▶ Complete with Ferrule for Making Service Connections & Direct Under Pressure Tapping in Water Mains
- ▶ Narrow & Broad Saddle Body & Tapping Internally Threaded on Various Type Materials Pipeline
- ▶ Tapping Outlet Sizes for Residential Homes, Commercial & Industrial Users
- ▶ Working Pressure : PN 16
- ▶ Coating : Fusion Bonded Epoxy
- ▶ Sealing : EPDM

## Standards

- ▶ Design & Test : Modified SPESIFIKASI JKR 20200-0184-04
  - ▶ Threads : MS ISO 7, BS 21
- |   |  |
|---|--|
| ▶ For Ductile Iron (DI) Pipe : BS EN 545, ISO 2531, MS 1919     | ▶ For UPVC Pipe : MS 628, BS 6920, BS 3505, AS/NZS 1477 S2 |
| ▶ For Mild Steel (MS) Pipe : BS 534, SPAN TS 21827, JKR, AS1579 | ▶ For PVC-M Pipe : AS/NZS 4765 S1                          |
| ▶ For AC Pipe : BS EN 512, MS 712                               | ▶ For MPVC Pipe : MS 628                                   |
|   | ▶ For PE Pipe : EN 12201, MS 1058                          |
|   | ▶ For PVC-O Pipe : ISO 16422                               |

## Features

- ▶ Full Size Range Available for Distribution System in Water Mains
- ▶ Various Tapping Outlet Sizes for Service Applications
- ▶ Designed for Easy Saddle Mounting, Maintenance Free & Longevity
- ▶ Saddle Body Designed for Furnishing Satisfactory Sealing & Preventing Pipe Movements & Distortion
- ▶ Broad Saddle Body with Large Profiled Gasket Sealing against Rough Surface of Plastic Pipeline

# DIRECT DRILL & TAP FERROUS SADDLES

FOR SERVICE CONNECTION & PRESSURE PIPE TAPPING THREADED INTERNALLY IN WATER MAINS

## Technical Table

### Narrow Saddle Body

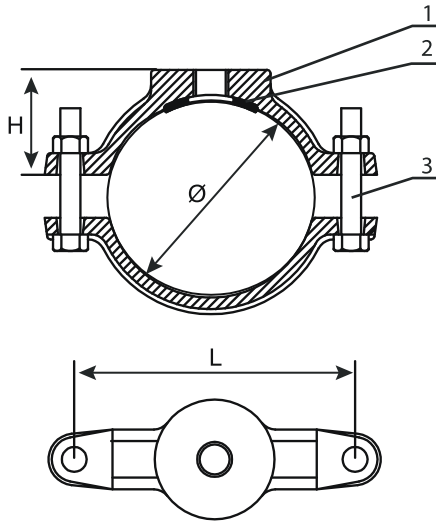

### Broad Saddle Body

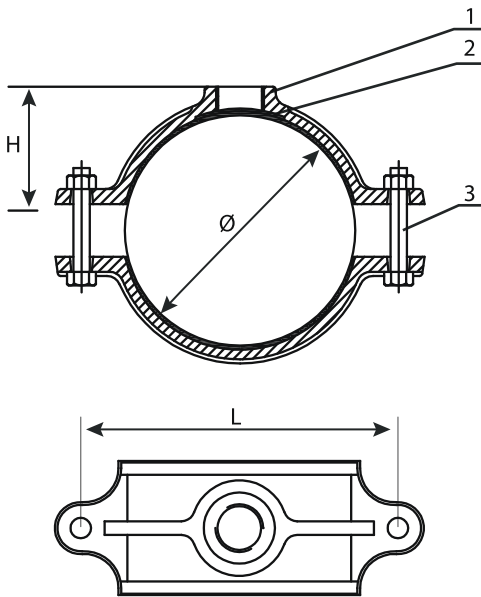

## Assembly Chart

No	Component	Material	Standard Ref.
1	Body	Ductile Iron	BS EN 1563
2	Sealing Gasket	EPDM	BS EN 681
3	Bolts & Nuts	Hot Dipped Galvanized	BS 4190

## Specifications & Parameters Chart (Narrow Saddle Body) For DI, MS & AC Pipes

DN (mm)	Ø (mm)	L (mm)	H (mm)	Bolts
80	95.6	144	51	M12x2
100	121.9	169	59	M12x2
150	177.3	224	89	M12x2
200	232.2	277	112	M16x2
250	286.0	338	137	M16x2
300	345.4	397	161	M16x2

Tapping Outlets Size Ranges : ½", ¾" to 1" BSP

## (Broad Saddle Body) For DI & MS Pipes

DN (mm)	Ø (mm)	L (mm)	H (mm)	Bolts
150	170	215	95	M14x2
200	222	272	121	M16x2
250	274	334	147	M16x2
300	326	387	173	M16x2

Tapping Outlets Size Range : 2"

## For UPVC & MPVC Pipes

DN (mm)	Ø (mm)	L (mm)	H (mm)	Bolts
80	88.9	137	54	M12x2
100	114.3	164	64	M12x2
150	168.3	232/215*	84/95*	M12x2
200	219.1	286/272*	114/121*	M16x2
250	273.0	336/334*	141/147*	M16x2
300	323.9	387/387*	170/173*	M16x2

Tapping Outlets Size Ranges : ½", ¾", 1" to 2" BSP

\*For Tapping Outlet Size: 2"

## For PE, PVC-O, PVC-M & Others Plastic Pipes with Similar OD

OD (mm)	Ø (mm)	L (mm)	H (mm)	Bolts
63	63	103	50	M12x2
90	90	145	58	M12x2
110	110	165	68	M12x2
125	125	193	81	M12x2
160	160	215/230*	95/100*	M16x2
180	180	235/250*	105/110*	M16x2
200	200	260/270*	115/120*	M16x2
225	225	285/296*	129/132.5*	M16x2
250	250	313/322*	140/145*	M16x2
280	280	343/352*	155/160*	M16x2
315	315	385/388*	175/177.5*	M16x2
355	355	415/430*	195/197.5*	M16x2

Tapping Outlets Size Ranges : ½", ¾", 1" to 2" BSP

\*For Tapping Outlet Size: 2"

Note: Technical data provided in this brochure is indicative only and may be subject to change without prior notice.